

ASSEMBLY INSTRUCTIONS

SOLID OAK VANITY CABINETS

实木浴室橱组装说明书（无抽屉的橱）

This instructions apply to all solid vanity cabinets without drawers.
 本安装说明书适用于所有无抽屉实木浴室橱的组装

Checking Your Parts

The following parts are included in this carton. Separate and check to see that all parts are accounted for before beginning assembly. If you are missing parts use the form enclosed and fax or mail to us or call us request that part(s) be sent to you.

PARTS LIST

A - Door Faceframe(1) B - Side Panels(2) C - Back Support(2) D - Floor(1) E - Toe Kick(1) F - Hardware Bag(1)

ASSEMBLY STEPS

STEP 1: Remove the vanity unit parts and make sure all are accounted for. Place the Door Faceframe(A) down on a flat soft surface to avoid scratching the cabinet.

STEP 2: Insert two Side Panels(B) into the grooves of Faceframe(A). Align the plastic half sections of the camlock connectors. Confirm all is flush and lock connectors with a screwdriver by turning the screw located on the camlock connector to the right 180 degrees, reference

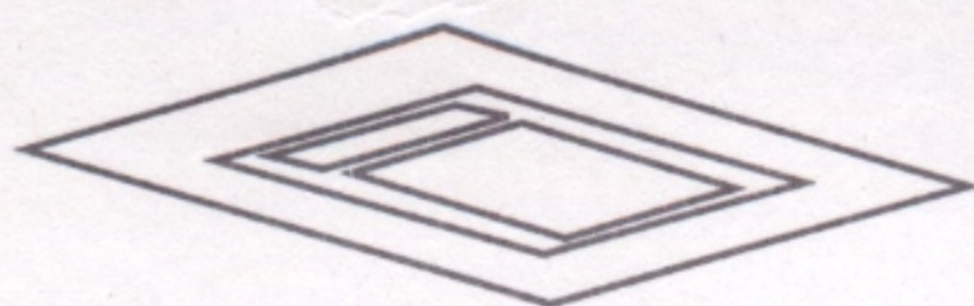

1) SOFT SURFACE

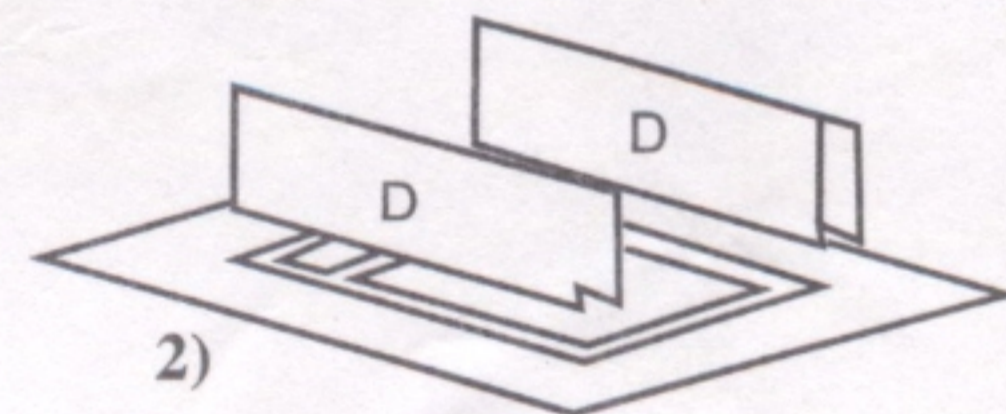
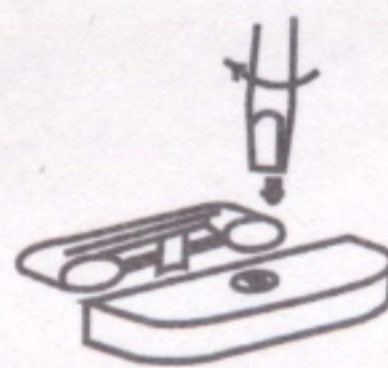

2)

figure A

STEP3: Insert Floor (D) into the grooves of Side Panels (B) and Faceframe(A).

STEP4: Position the Bottom Back Support (C) onto Side Panels (B) so that the groove in the back support fits over the Floor (D). Confirm that all is flush and lock the camlockconnectors as above. Now position the Top Back Support (C) onto the side panels at the camlock connectors and lock as above. Position Toe Kick (E) onto Side Panels at the front base of the vanity, confirm all is flush and lock the connectors. Stand the cabinet upright at this time.

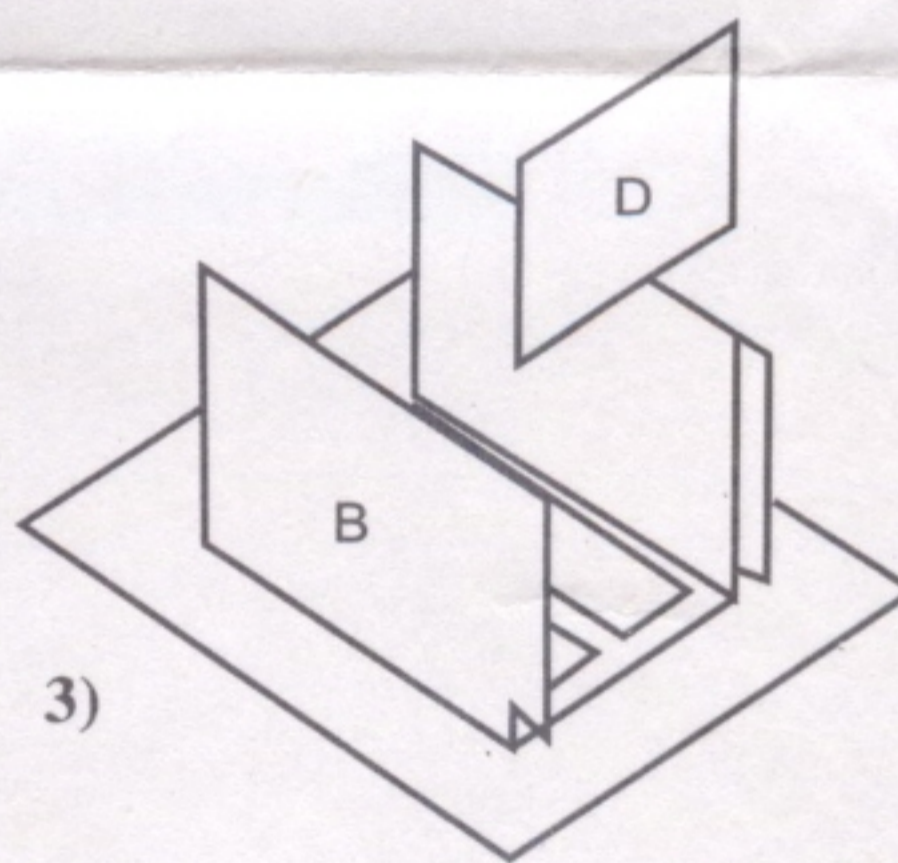

3)

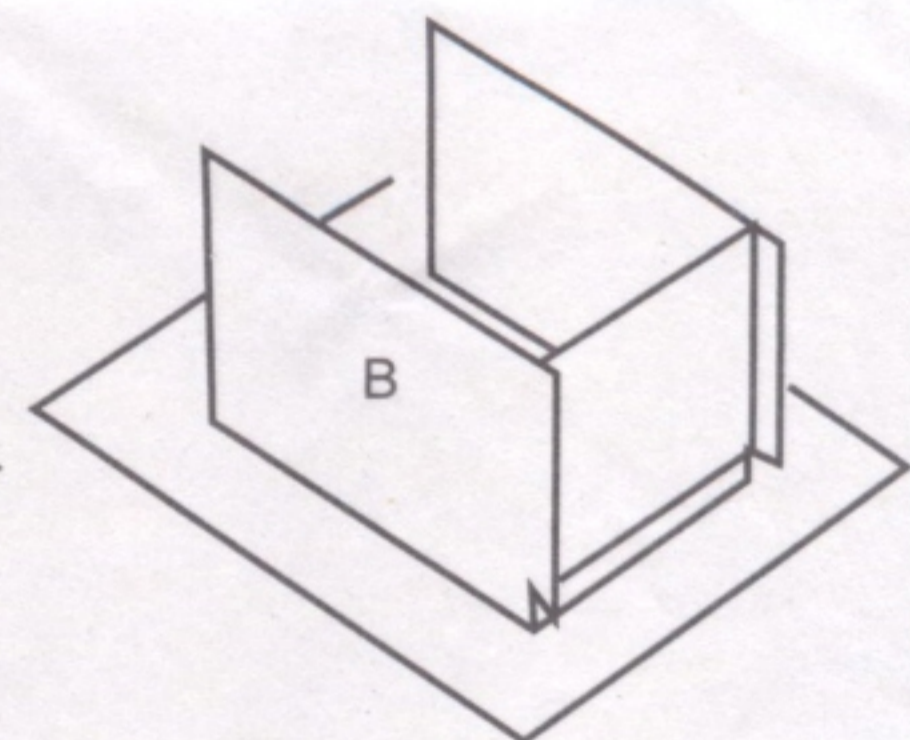

STEP5: Remove Door Pulls from the hardware bag and mount to Doors & Drawers.

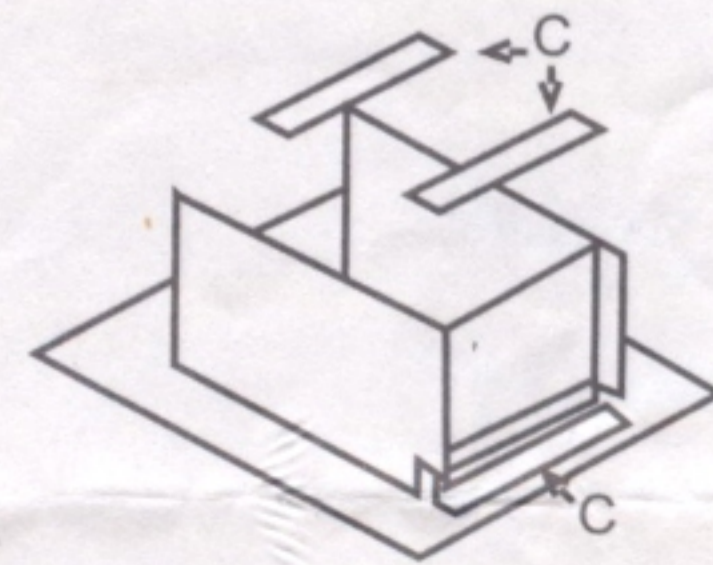

4)

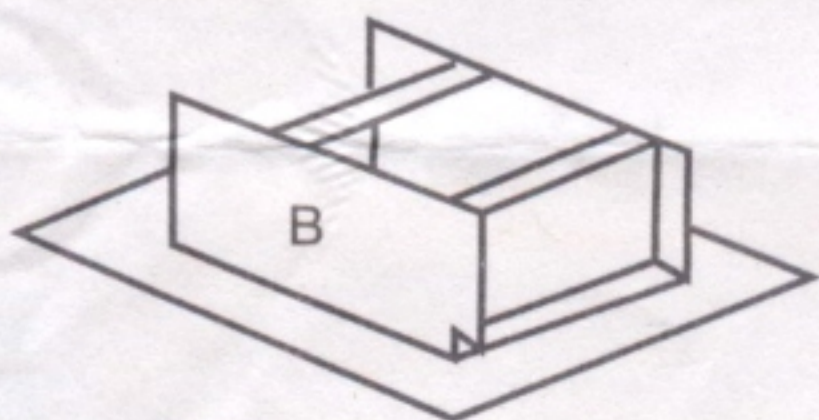

5)

